

THIS DRAWING IS UNPUBLISHED. RELEASED FOR PUBLICATION
 © COPYRIGHT BY TYCO ELECTRONICS CORPORATION. ALL RIGHTS RESERVED.

LOC	DIST	REVISIONS					
G	14	P	LTR	DESCRIPTION	DATE	DWN	APVD
		L2		MISSING WORD "WASHER"	28JUL04	JR	CK

AMP PART NO	MATERIAL	PKG TYPE	QTY
8-36917-3	M/F 8-36917-0	BOX	25
8-36917-5	M/F 8-36917-0	BAG	5

AMP WIRE RANGE	Listed FILE E13288	LR7189 Certified
1/0 AWG STRANDED	1/0 AWG STRANDED	1/0 AWG STRANDED

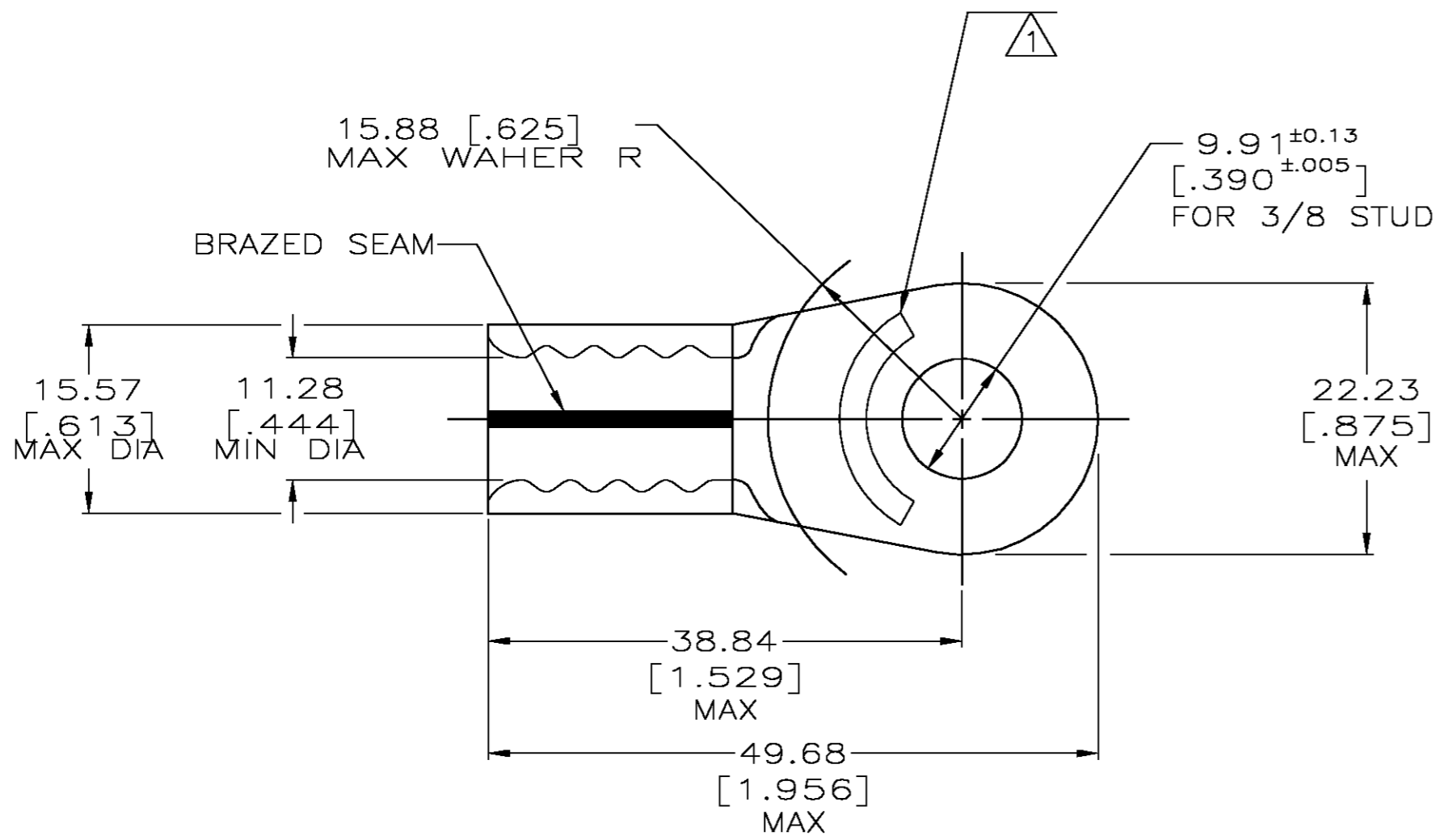

- 1 STAMP AMP 1/0W* APPROX AS SHOWN
- 2 MATERIAL THK: 1.78 ±0.08 [0.070 ±0.003]
- 3 0.00254 [0.000100] MIN TIN PLATE PER ASTM B-545

AMP INCORPORATED CUSTOMER SERVICE SYSTEMS		MAX RECOMMENDED OPERATING TEMPERATURE: 170° C MAX
FOR ADDITIONAL PRODUCT INFORMATION OR COPIES OF DRAWINGS AND TECHNICAL DOCUMENTS	PRODUCT INFORMATION CENTER 1-800-522-6752	VOLTAGE RATING: N/A
FOR APPLICATION TOOLING INFORMATION	TOOLING ASSISTANCE CENTER 1-800-722-1111	CIRCULAR MIL AREA: 42.4-60.6mm ² [83,700-119,500] SOLID OR STRANDED
FOR ORDER ENTRY	1-800-526-5142	THIS DRAWING IS A CONTROLLED DOCUMENT FOR AMP INCORPORATED. IT IS SUBJECT TO CHANGE AND THE CONTROLLING ENGINEERING ORGANIZATION SHOULD BE CONTACTED FOR THE LATEST REVISION.

THIS DRAWING IS A CONTROLLED DOCUMENT.		DWN DK SCHRUM 7/21/91	Tyco Electronics Corporation Harrisburg, Pa 17105-3608	
DIMENSIONS: MM [INCHES]		CHK RD HEIM 8/15/91	NAME AJ KAUFFMAN 8/15/91	
TOLERANCES UNLESS OTHERWISE SPECIFIED: 0 PLC ± - 1 PLC ± - 2 PLC ± 0.20[.008] 3 PLC ± - 4 PLC ± - ANGLES ± -		APVD AJ KAUFFMAN 8/15/91	PRODUCT SPEC APPLICATION SPEC	
MATERIAL COPPER ASTM B-152 ANNEALED		FINISH -3	WEIGHT -	SIZE A2
CAGE CODE 00779		DRAWING NO C=36917	RESTRICTED TO -	
CUSTOMER DRAWING		SCALE 2:1	SHEET 1 OF 1	REV L2